

Application

VB-7312 series three-way mixing valves control hot or chilled water from 20 to 281°F (-7 to 138°C) in heating or air conditioning systems. These valves must be piped with two inlets ("A" and "B" ports) and one outlet ("AB" port). They are used for two-position or proportional control applications. Valve assemblies require an actuator and a valve linkage that must be purchased separately.

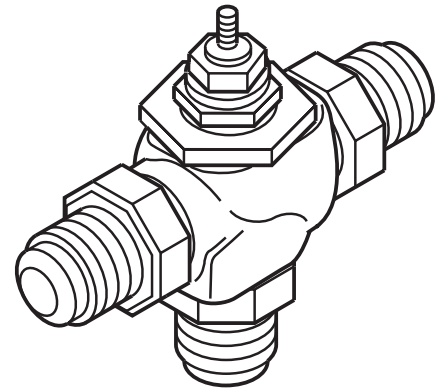

Danger: Do not use for combustible gas applications. The VB-7312 series valve packings are not rated for combustible gas applications, and if used in these applications, gas leaks and explosions could result.



Features

- 250 psig pressure rating per ANSI Standards (B16.15–1985) for cast bronze bodies
- Spring-loaded TFE packing
- 5/8" O.D., 45° SAE flared end fittings

Applicable Literature

- TAC Valve Products Catalog, F-27384
- TAC Cross-Reference Guide, F-23638
- TAC Reference Manual, F-21683
- TAC Application Manual, F-21335
- Control Valve Sizing, F-13755
- Valve Selection Chart for Water, F-11080
- EN-205 Water System Guidelines, F-26080

SPECIFICATIONS

Table-1 Specifications/Models.

Specifications			Valve Body Series VB-7312-0-4-P
Service			Chilled or Hot Water
Flow Characteristics (Figure-1)			Mixing
Size			5/8" O.D.
Type of End Fitting			45° SAE Flared
Valve Materials	Body		Bronze
	Seat		Bronze
	Stem		Stainless Steel
	Plug		Brass
	Packing		Spring-loaded TFE
	Disc		None
ANSI Pressure Class (Figure-2)			250 (up to 400 psig below 150°F) ^a
Maximum Inlet Pressure, Water			35 psig (241 kPa)
Allowable Control Media Temperature			20 to 281°F (-7 to 138°C)
Allowable Differential Pressure for Water ^b			35 psi (241 kPa) Max. for Normal Life (refer to "Cavitation Limitations on Valve Pressure Drop" on page 5)
Valve Size	C _v Rating	k _{vs} Rating ^c	Complete Valve Body Part Number
1/2"	2.2	1.9	VB-7312-0-4-2
	4.4	3.8	VB-7312-0-4-4

^a Do not apply above pressure rating to piping system.

^b Maximum recommended differential pressure in open position. Do not exceed recommended differential pressure (pressure drop) or integrity of parts may be affected. Exceeding maximum recommended differential pressure voids product warranty.

^c $k_{vs} = m^3/h$ ($\Delta P = 100$ kPa) $C_v = k_{vs} \times 1.156$

Close-off Pressure Rating

The close-off pressure rating is dependent on the size of the valve, valve linkage, and actuator. Consult the **TAC Valve Products Catalog, F-27384**, for close-off ratings.

Normal Position of Valve Assembly

For a valve assembly (valve, linkage, and actuator) to have a normal (spring return) position, the actuator must be of the spring return type. See Table-2 for the normal position of the valve assemblies.

Table-2 Required Compatible Actuators/Linkages.

Actuator Series	Required Valve Linkage	Normal Position
MA-5210, MA-5211, MA-5213	AV-7600 ^a	Flow Port "B" to Port "AB"
MF-5413, MF-5513		
MF-22203, MF-22303, MF-22323	Included w/Actuator	
MK-2690	AV-7400	
MK-4601, MK-4611, MK-4621	AV-401	
MP-5210, MP-5211, MP-5213	AV-7600 ^a	
MP-5410, MP-5411, MP-5413	AV-7600 & AV-601	
MP-5513		
MPR-5610, MPR-5611, MPR-5613		
MPR-5713		
MS-22353	Included w/Actuator	

^a High ambient temperatures with high media temperatures in the valve may require the use of AV-601 in addition to AV-7600. See General Instructions for AV-7600 (F-26235) and AV-601 (F-19069) for details.

Flow Characteristics

Three-way mixing valves are designed so that the flow from either of the inlet ports to the outlet is approximately linear, which means the total flow from the outlet is almost constant over the stroke of the valve stem. See Figure-1 for typical characteristic of VB-7312 series valve bodies.

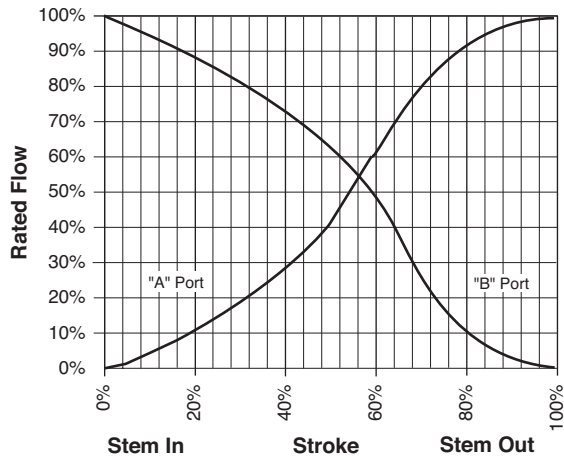

Figure-1 Typical Flow Characteristics.

Rangeability

Rangeability is the ratio of rated flow to the minimum controllable flow through a valve. For mixing valves, control begins as soon as plug displacement allows flow. Thus, three-way valve rangeability normally exceeds 500:1, which is the reciprocal of 0.2% nominal leakage.

Temperature/Pressure Ratings

See Figure-2 for temperature and pressure ratings. Consult the appropriate valve linkage general instruction sheet for the effect of valve body ambient temperatures on specific actuators. Ratings conform with published values and disclaimer.

VB-7312-0-4-P (45° SAE Flared Cast Bronze Body)

Standards: Pressure to ANSI B16.15 Class 250 with 400 psig up to 150°F decreasing to 321 psig at 281°F

Materials: Bronze, ASTM B584

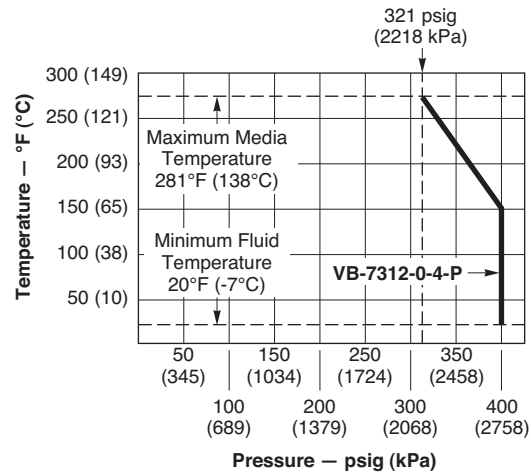

Figure-2 Temperature and Pressure Ratings for VB-7312 Series Valve Bodies.

VALVE SIZING AND SELECTION

Water

Two-position

Two-position control valves are normally selected “line size” to keep pressure drop at a minimum. If it is desirable to reduce the valve below line size, then 10% of “available pressure” (that is, the pump pressure differential available between supply and return mains with design flow at the valve location) is normally used to select the valve.

Proportional to Bypass Flow

Proportional valves used to bypass flow (Figure-3) are piped on the outlet side of the load to throttle the water flow through the load and therefore control heat output of the load. These valves are usually selected to take a pressure drop equal to at least 50% of the “available pressure.” As “available pressure” is often difficult to calculate, the normal procedure is to select the valve using a pressure drop at least equal to the drop in the coil or other load being controlled (except where small booster pumps are used) with a minimum recommended pressure drop of 5 psi (34 kPa). When the design temperature drop is less than 60°F (33°C) for conventional heating systems, higher pressure drops across the valve are needed for good results (Table-3).

Table-3 Conventional Heating System.

Design Temperature Load Drop °F (°C)	Recommended Pressure Drop ^a (% of Available Pressure)	Multiplier on Load Drop
60 (33) or More	50%	1 x Load Drop
40 (22)	66%	2 x Load Drop
20 (11)	75%	3 x Load Drop

^a Recommended minimum pressure drop = 5 psi (34 kPa).

Secondary Circuits with Small Booster Pumps: 50% of available pressure difference (equal to the drop through load, or 50% of booster pump head).

Proportional to Blend Water Flows

Proportional valves used to blend two water flows (Figure-4 and Figure-5) control the heat output by varying the water temperature to the load at constant flow. These valves do not require high pressure drops for good control results. They can be sized for a pressure drop of 20% of the “available pressure” or equal to 25% of the pressure drop through the load at full flow.

Water Capacity

See Table-4 for water capacity of VB-7312 series valves.

Table-4 Water Capacity in Gallons Per Minute for VB-7312 Series.

Valve Body Part Number	C _v Rating	Differential Pressure (ΔP in psi)												
		1	2	3	4	5	6	7	8	9	10	15	20	35
VB-7312-0-4-2	2.2	2.2	3.1	3.8	4.4	4.9	5.4	5.8	6.2	6.6	7.0	8.5	9.8	13
VB-7312-0-4-4	4.4	4.4	6.2	7.6	8.8	9.8	11	12	12	13	14	17	20	26

C_v Equation

$$C_v = \frac{\text{GPM}}{\sqrt{\Delta P}} \quad \Delta P = \left(\frac{\text{GPM}}{C_v} \right)^2 \quad \text{GPM} = C_v \sqrt{\Delta P}$$

Where:

C_v = Coefficient of flow

GPM = U.S. gallons per minute (60°F, 15.6°C)

ΔP = Differential pressure in psi (pressure drop)

Cavitation Limitations on Valve Pressure Drop

A valve selected with too high a pressure drop can cause erosion of discs and/or wire drawing of the seat. In addition, cavitation can cause noise, damage to the valve trim (and possibly the body), and choke the flow through the valve.

Do not exceed the maximum differential pressure (pressure drop) for the valve selected.

The following formula can be used on higher temperature water systems, where cavitation could be a problem, to estimate the maximum allowable pressure drop across the valve:

$$P_m = 0.5 (P_1 - P_v)$$

Where:

P_m = Maximum allowable pressure drop (psi)

P_1 = Absolute inlet pressure (psia)

P_v = Absolute vapor pressure (psia) (refer to Table-5)

Note: Add 14.7 psi to gauge supply pressure to obtain absolute pressure value.

For example, if a valve is controlling 200°F water at an inlet pressure of 18 psig, the maximum pressure drop allowable would be:

$$P_m = 0.5 [(18 + 14.7) - 11.53] = 10.6 \text{ psi}$$

(Vapor pressure of 200°F water is 11.53 psia.)

If the pressure drop for this valve is less than 10.6 psi, cavitation should not be a problem.

Systems where cavitation is shown to be a problem can sometimes be redesigned to provide lower inlet velocities. Valves having harder seat materials should be furnished if inlet velocities cannot be lowered.

Table-5 Vapor Pressure of Water Table.

Water Temp. (°F)	Vapor Pressure (psia)	Water Temp. (°F)	Vapor Pressure (psia)	Water Temp. (°F)	Vapor Pressure (psia)	Water Temp. (°F)	Vapor Pressure (psia)
40	0.12	90	0.70	140	2.89	190	9.34
50	0.18	100	0.95	150	3.72	200	11.53
60	0.26	110	1.28	160	4.74	210	14.12
70	0.36	120	1.69	170	5.99	220	17.19
80	0.51	130	2.22	180	7.51	230	20.78

Additional Valve Sizing Information

For additional valve sizing information, see:

- CA-28 Control Valve Sizing, F-13755
- Valve Selection Chart Water, F-11080
- Valve Sizing Slide Rule, TOOL-150

INSTALLATION

Inspection

Inspect the package for damage. If damaged, notify the appropriate carrier immediately. If undamaged, open the package and inspect the device for obvious damage. Return damaged products.

Requirements

- Training: Installer must be a qualified, experienced technician
- Appropriate accessories

Caution:

- Install the valve with the flow in the direction of the flow arrows ("A" and "B" ports are the inlets and "AB" port is the outlet).
 - Do not exceed the ratings of the device.
 - Avoid locations where excessive moisture, corrosive fumes, or vibration are present.
-

Mounting

1. The valve should be mounted in a weather protected area in a location that is within the ambient limits of the actuator. When selecting a location, allow sufficient room for valve linkage, actuator, and other accessories and for service of the product.
2. The preferred mounting position for the valve is with the valve stem vertical above the valve body. Avoid mounting the valve so that the valve stem is below horizontal.
3. On steam applications where the ambient temperature approaches the limit of the actuator, the valve stem should be mounted 45° from vertical.
4. The VB-7312 series of flared valve bodies conform to SAE 45°. The valves must be piped with two inlets ("A" and "B" ports) and one outlet ("AB" port).

TYPICAL PIPING

All piping must comply with local codes and ordinances. Refer to Figure-3 through Figure-5 for typical piping.

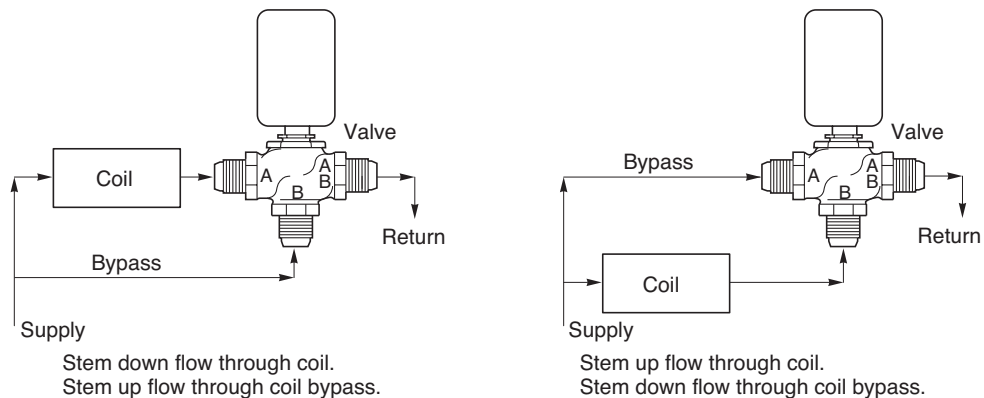

Figure-3 Typical Piping for Control of Heating or Cooling Coil.

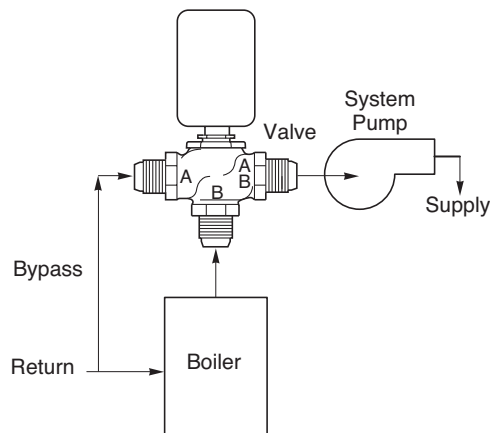

Figure-4 Typical Boiler Piping When Used in a Hot Water Reset Application.

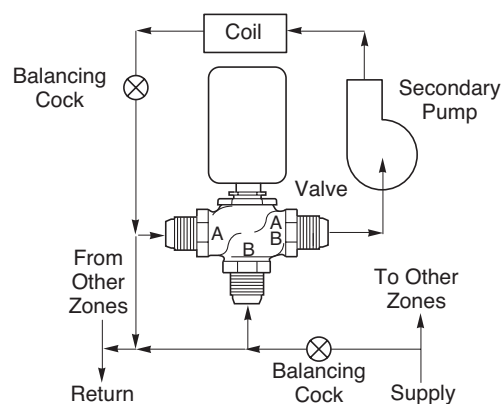

Figure-5 Typical Primary-Secondary Piping.

CHECKOUT

1. Make sure the valve stem operates smoothly before installing the valve linkage and the actuator.
2. If the stem does not operate smoothly, it may indicate that the valve was twisted or crushed during installation or that the stem was bent by rough handling. These conditions may require that the valve be replaced.
3. After the piping is under pressure, check the valve body and the connections for leaks.
4. After the valve linkage and the actuator are installed, check their operation.

MAINTENANCE & FIELD REPAIR

Regular maintenance of the total system is recommended to assure sustained performance. See Table-6 for maintenance kit part numbers.

Table-6 Maintenance Kits for VB-7312 Valves.

Valve Body Part Number	Replacement Packing Assembly	Packing Wrench	Valve Repair Kit ^a
VB-7312-0-4-2	YBA-622-1	TOOL-20-1	RYB-731-2
VB-7312-0-4-4			RYB-731-4

^a Kit includes replacement packing and stem & plug assembly.

Water System Maintenance

All heating and cooling systems are susceptible to valve and system problems caused by improper water treatment and system storage procedures. These guidelines are provided to help avoid valve and water system problems resulting from improperly treated water or storage procedures in cooling and hot water systems, and to obtain maximum life from TAC valves.

Durability of valve stems and packings is dependent on maintaining non-damaging water conditions. Inadequate water treatment or filtration, not in accordance with chemical supplier/ASHRAE handbook recommendations, can result in corrosion, scale, and abrasive particle formation. Scale and particulates can result in stem and packing scratches and can adversely affect packing life and other parts of the hydronic system.

To maintain non-damaging conditions, follow these guidelines:

- Clean the system prior to start up. Use a nitrite or molybdate-based treatment program.
- Use filtration equipment where needed.
- Properly store off-line systems and monitor water treatment results using corrosion test coupons.
- Follow the advice of a water treatment professional.
- Consult **EN-205, Water System Guidelines Engineering Information, F-26080**, for further details.

DIMENSIONAL DATA

Table-7 Dimensions for VB-7312 Series Valves (Figure-6).

Valve Body Part Number	Valve Size	Dimensions in Inches (mm)				
		A	B	C	D (Stem Down)	E (Stroke)
VB-7312-0-4-2	5/8"	4	2-1/4	1-11/16	3/4	7/16
VB-7312-0-4-4	O.D.	(102)	(57)	(43)	(19)	(11)

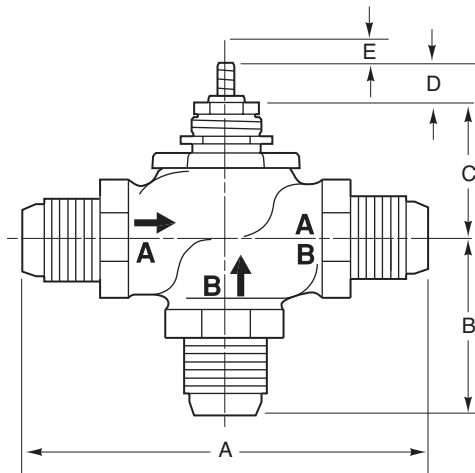

Figure-6 Dimensions for VB-7312 Series Valve Bodies.